

18 ASPHALT TO (E) ASPHALT TRANSITION
 3" = 1'-0"

CHARACTER REQUIREMENTS:

A. CHARACTER REQUIREMENTS FOR ALL SIGNS PER CBC 11B-703:

- 3 CHARACTERS SHALL BE UPPERCASE
- CHARACTERS SHALL BE SANS SERIF. CHARTERS SHALL NOT BE ITALIC, OBLIQUE, SCRIPT, HIGHLY DECORATIVE, OR OF OTHER UNUSUAL FORMS
- CHARACTER SHALL BE SELECTED FROM FONTS WHERE THE WIDTH OF THE UPPERCASE LETTER 'O' IS 60 PERCENT MINIMUM AND 110 PERCENT MAXIMUM OF THE HEIGHT OF THE UPPERCASE LETTER 'T'
- SPACINGS BETWEEN THE BASELINES OF SEPARATE LINES OF RAISED CHARACTERS WITHIN A MESSAGE SHALL BE 135 PERCENT MINIMUM AND 170 PERCENT MAXIMUM OF THE CHARACTER HEIGHT
- TEXT SHALL BE IN HORIZONTAL FORMAT
- CHARACTERS AND THEIR BACKGROUND SHALL HAVE A NON-GLARE FINISH AND CONTRAST WITH ONE ANOTHER

B. RAISED CHARACTER REQUIREMENTS FOR SIGNS WITH BRAILLE PER CBC 11B-703.2:

- RAISED CHARACTERS SHALL COMPLY WITH REQUIREMENTS NOTED IN PARAGRAPH 'A' ABOVE
- RAISED CHARACTERS SHALL BE 1/32 INCH MIN ABOVE BACKGROUND
- RAISED CHARACTER HEIGHT MEASURED VERTICALLY FROM THE BASELINE OF THE CHARACTER SHALL BE 9/8 INCH MINIMUM AND 2 INCHES MAXIMUM BASED ON THE HEIGHT OF THE UPPERCASE LETTER 'T'
- STROKE THICKNESS OF THE UPPERCASE LETTER 'T' SHALL BE 10 PERCENT MINIMUM AND 15 PERCENT MAXIMUM OF THE HEIGHT OF THE CHARACTER
- CHARACTER SPACING BETWEEN INDIVIDUAL RAISED LETTERS SHALL BE 1/8 INCH MINIMUM AND FOUR (4) TIMES THE RAISED CHARACTER STROKE WIDTH MAXIMUM
- ALL EDGES ON GEOMETRIC SYMBOLS SHALL BE EASED OR ROUNDED AT 1/16 INCH MINIMUM. VERTICES SHALL BE RADIUS BETWEEN 1/8 INCH MINIMUM AND 1/4 INCH MAXIMUM.

C. VISUAL CHARACTER REQUIREMENTS FOR SIGNS WITHOUT BRAILLE PER CBC 11B-703.5:

- VISUAL CHARACTERS SHALL COMPLY WITH REQUIREMENTS NOTED IN PARAGRAPH 'A' ABOVE
- MINIMUM CHARACTER HEIGHT SHALL CONFORM TO 2016 CBC TABLE 11B-703.5.5 BUT IN NO CASES SHALL BE LESS THAN 5/8 INCH
- HEIGHT FROM FINISH FLOOR SHALL BE NO LESS THAN 40 INCHES
- STROKE THICKNESS OF THE UPPERCASE LETTER 'T' SHALL BE 10 PERCENT MINIMUM AND 20 PERCENT MAXIMUM OF THE HEIGHT OF THE CHARACTER
- SPACINGS BETWEEN INDIVIDUAL CHARACTERS SHALL BE 10 PERCENT MINIMUM AND 35 PERCENT MAXIMUM OF CHARACTER HEIGHT.

CHARACTER AND STROKE WIDTH TO HEIGHT PROPORTIONS:

CHARACTER WIDTH (UPPERCASE LETTER 'O')	CHARACTER THICKNESS (UPPERCASE LETTER 'T')
1.1 MAX (110%)	1.5 MAX (15%)
3.5 MIN (60%)	1.1 MIN (10%)
3.20 MAX (TACTILE)	2.0 (TACTILE)

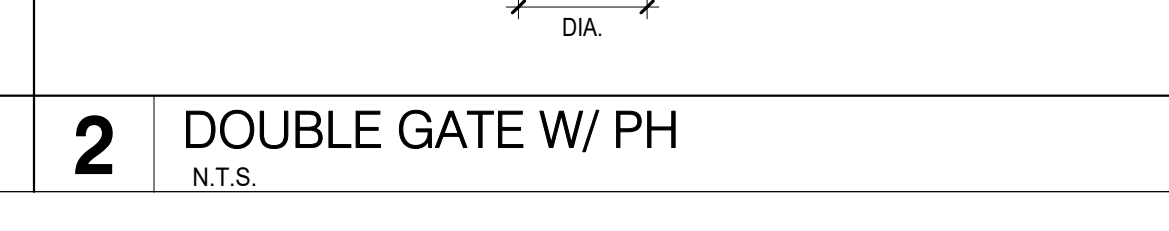
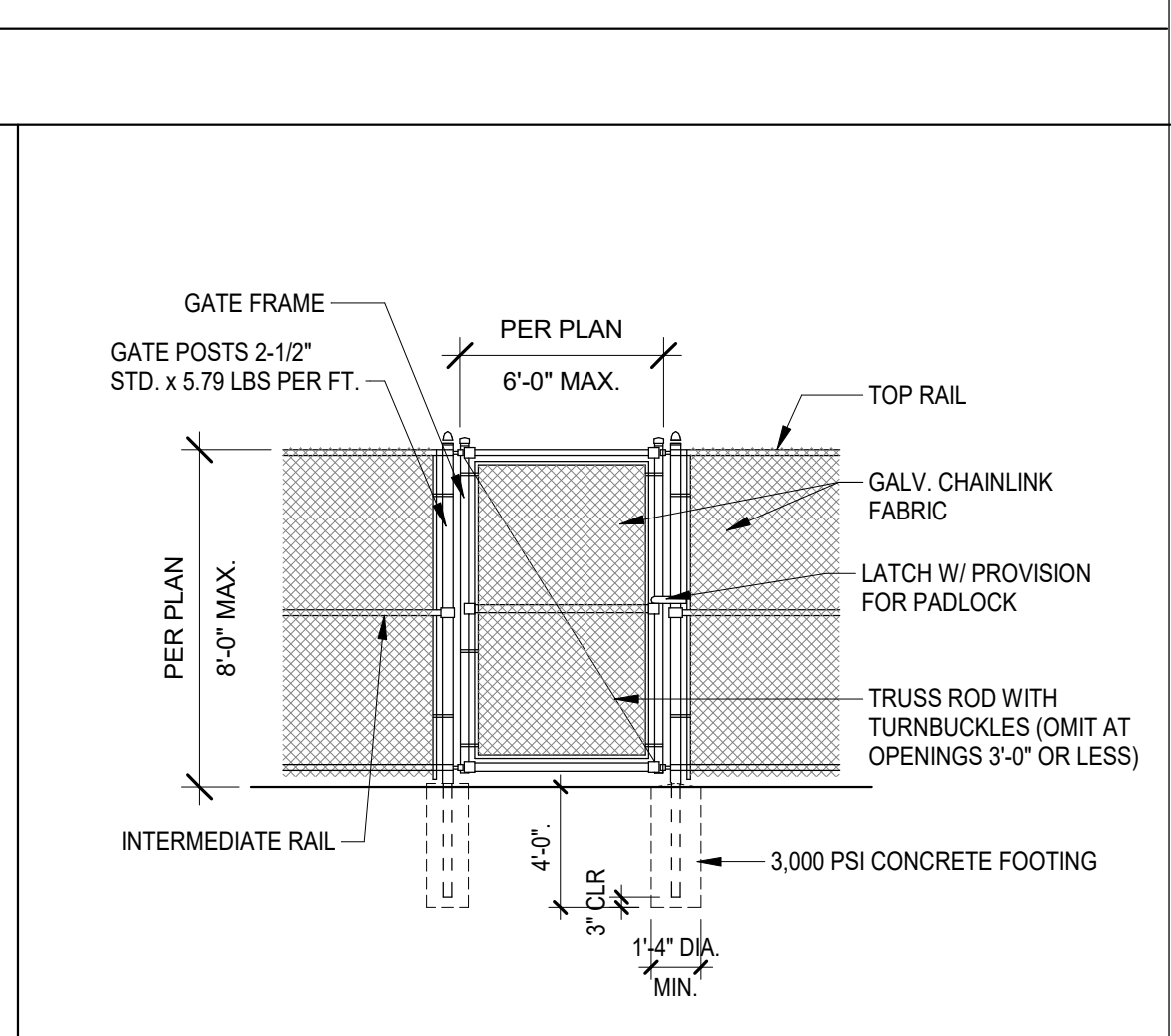
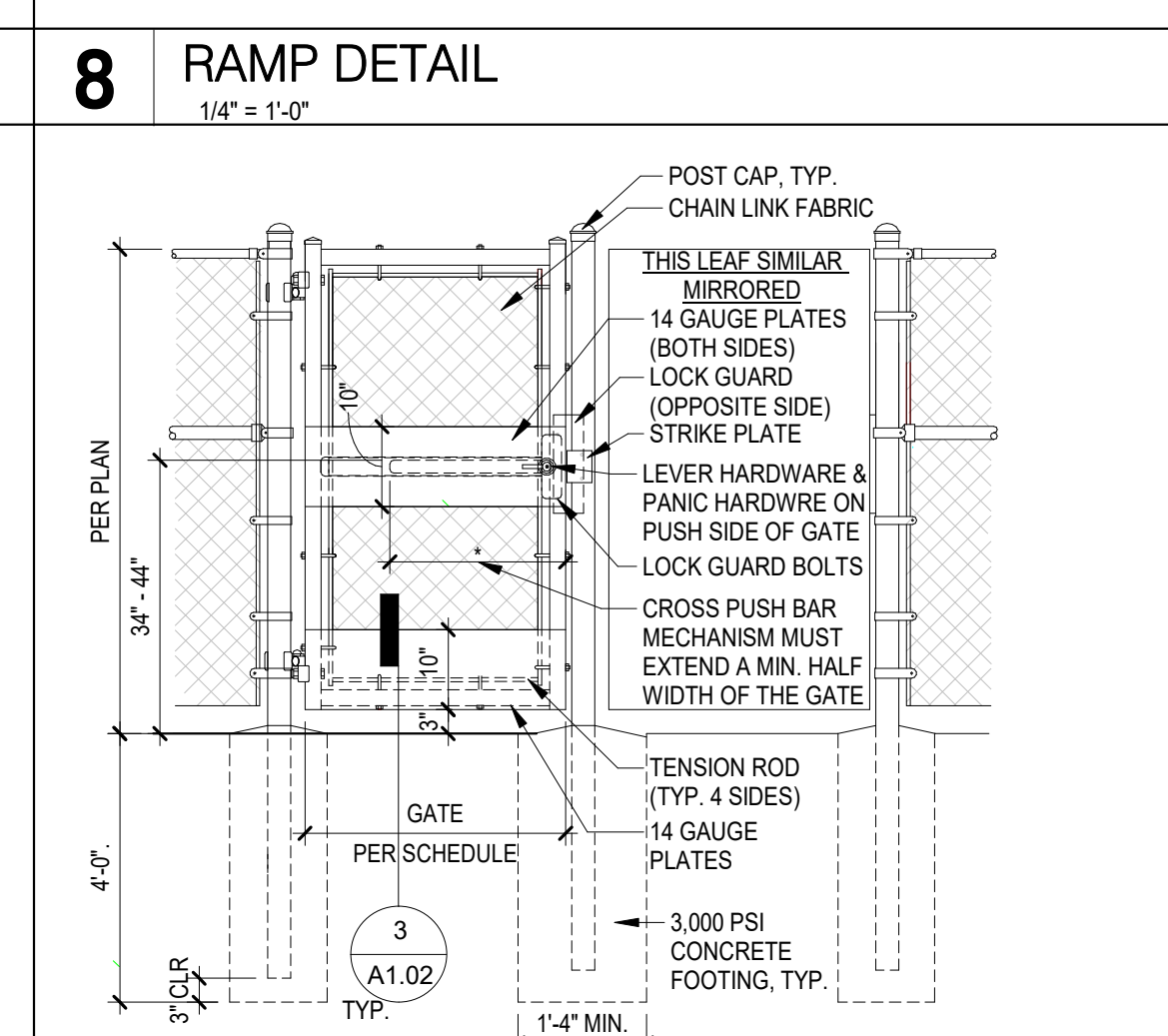
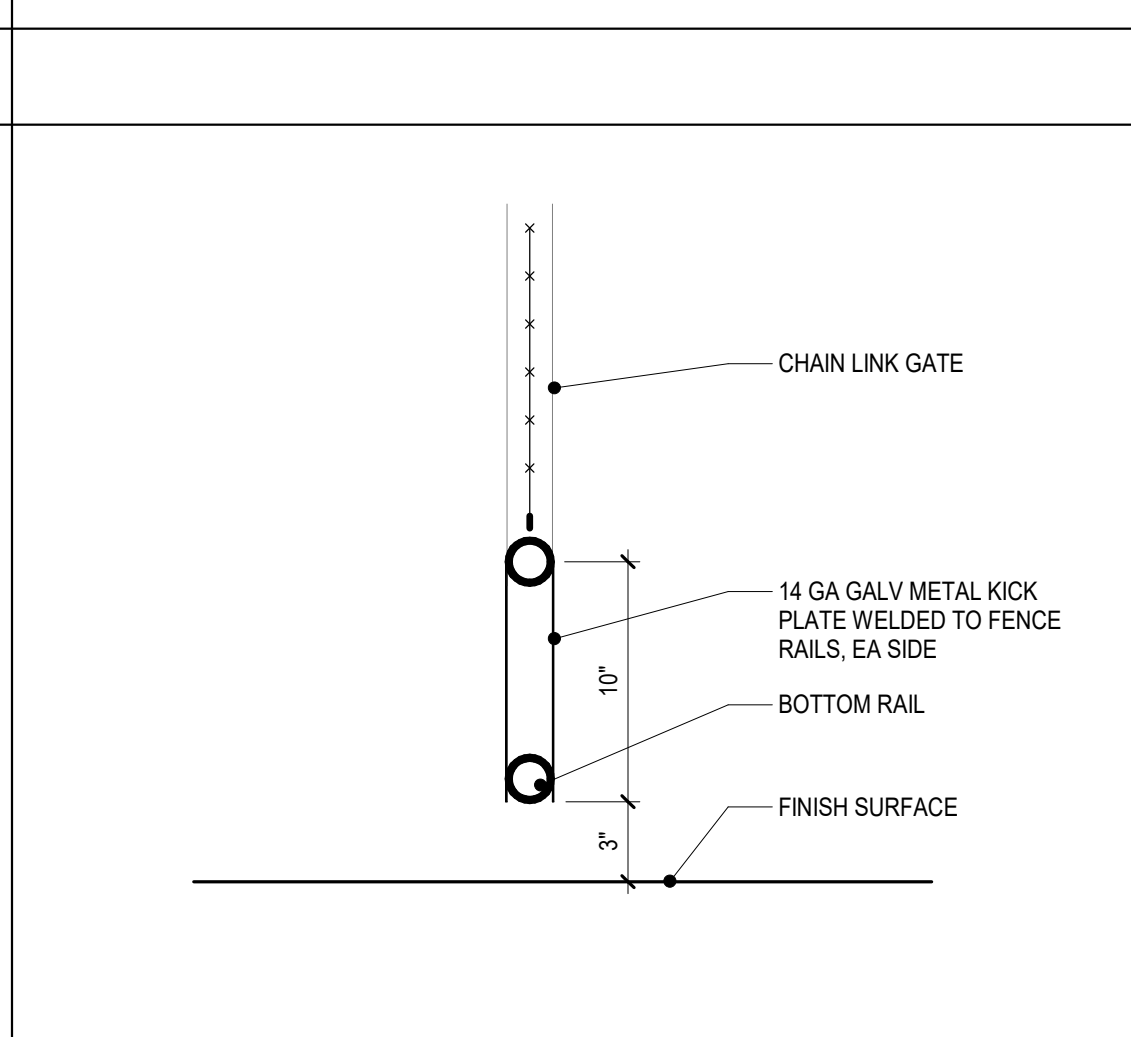
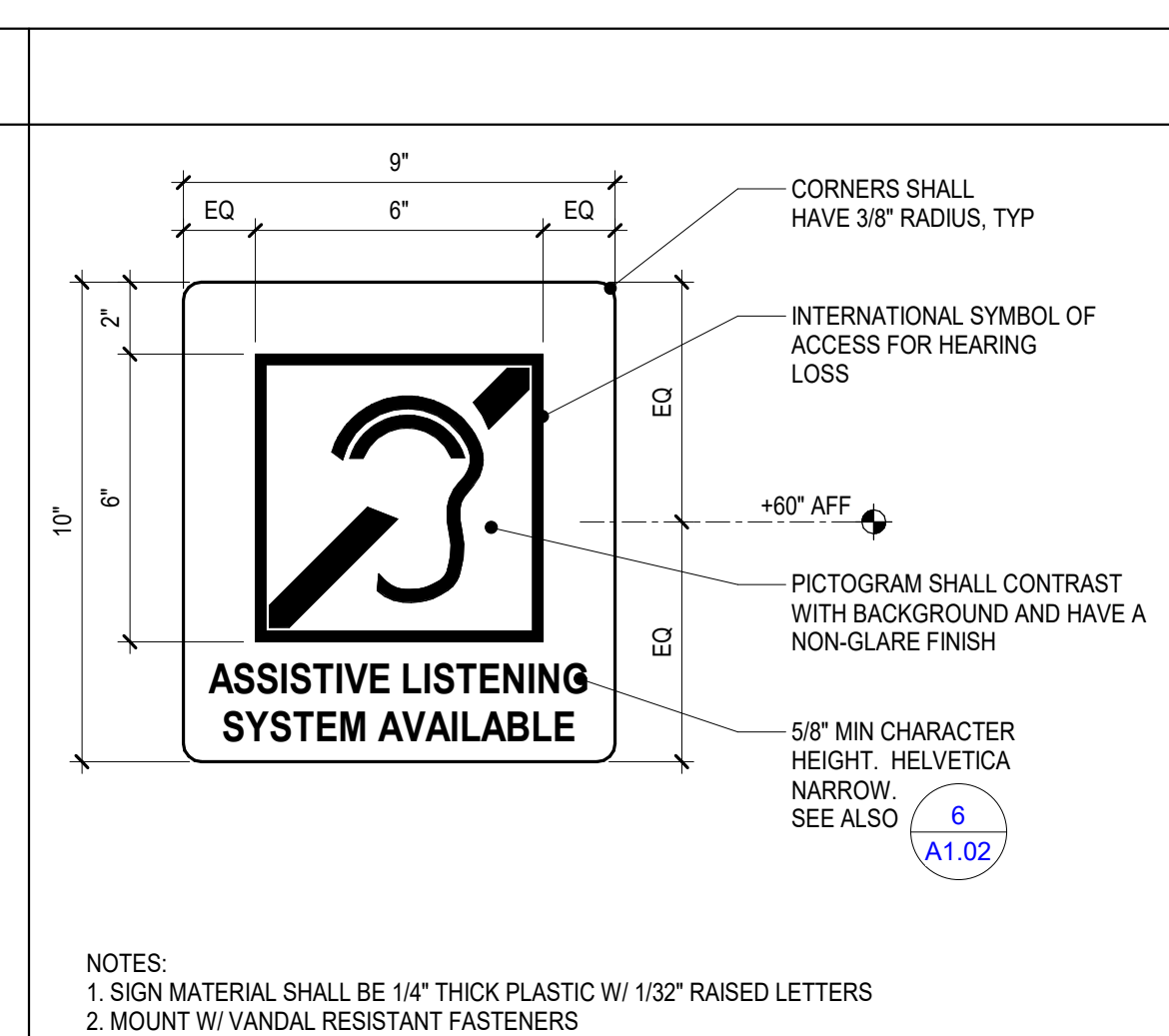
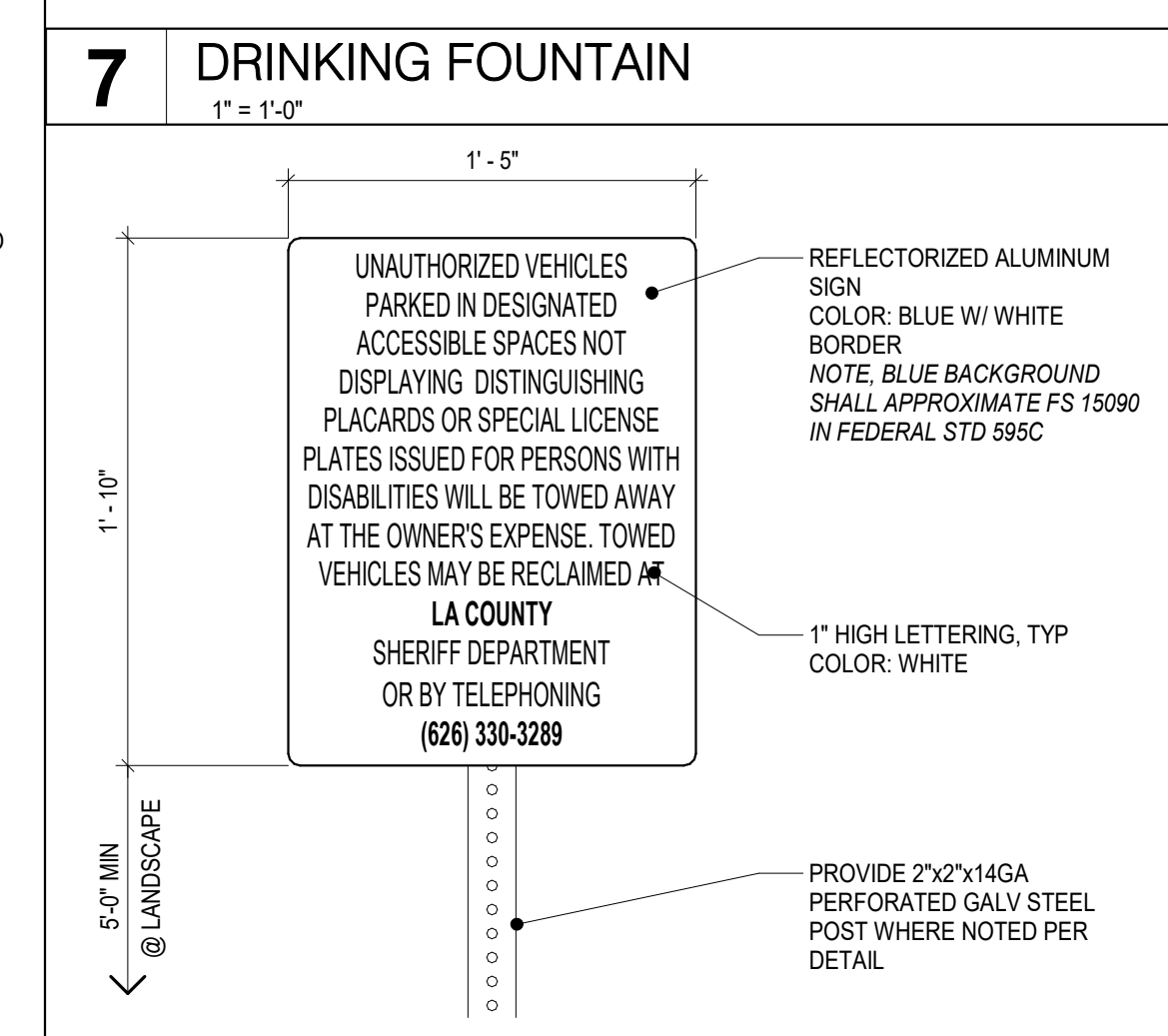
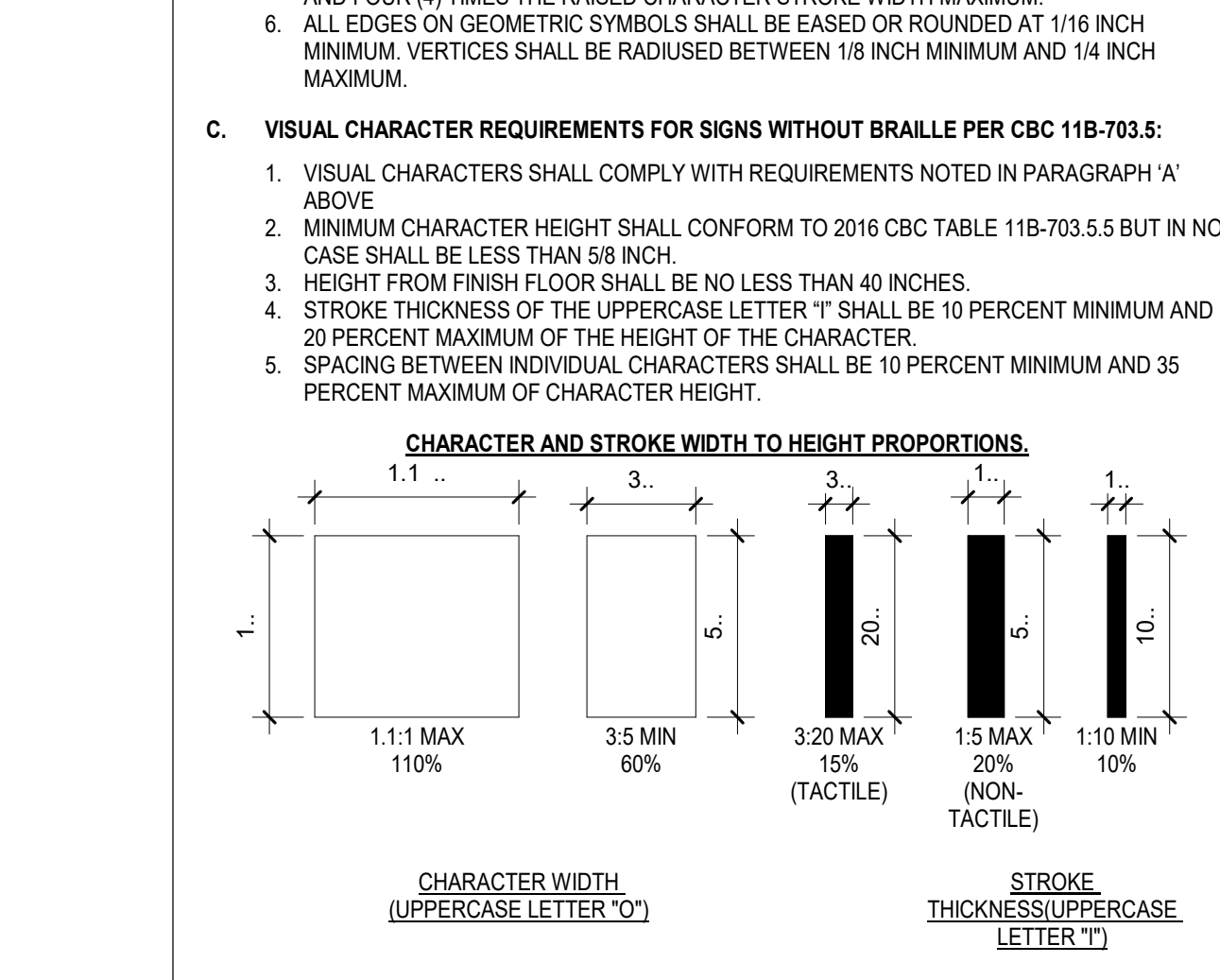
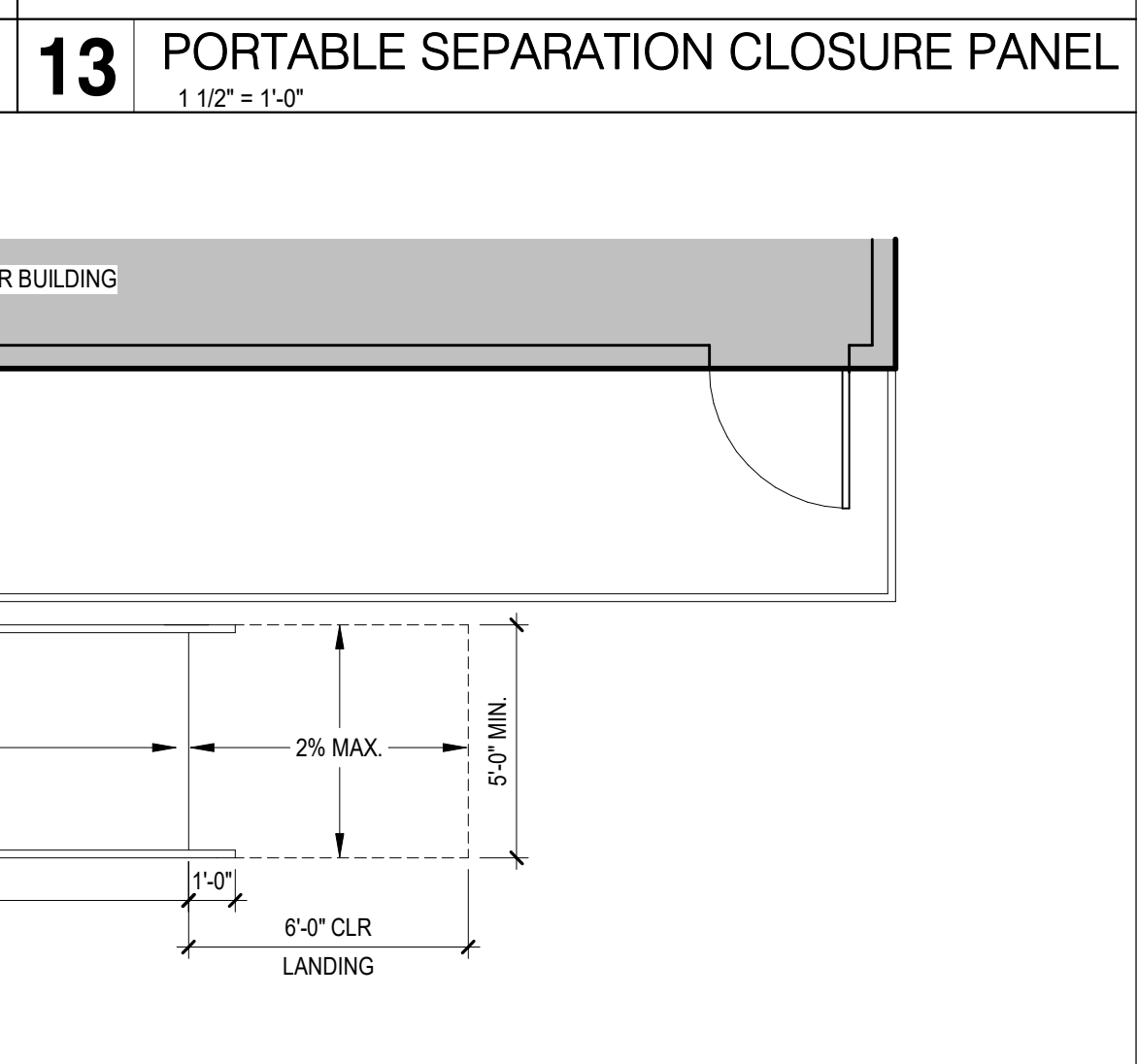
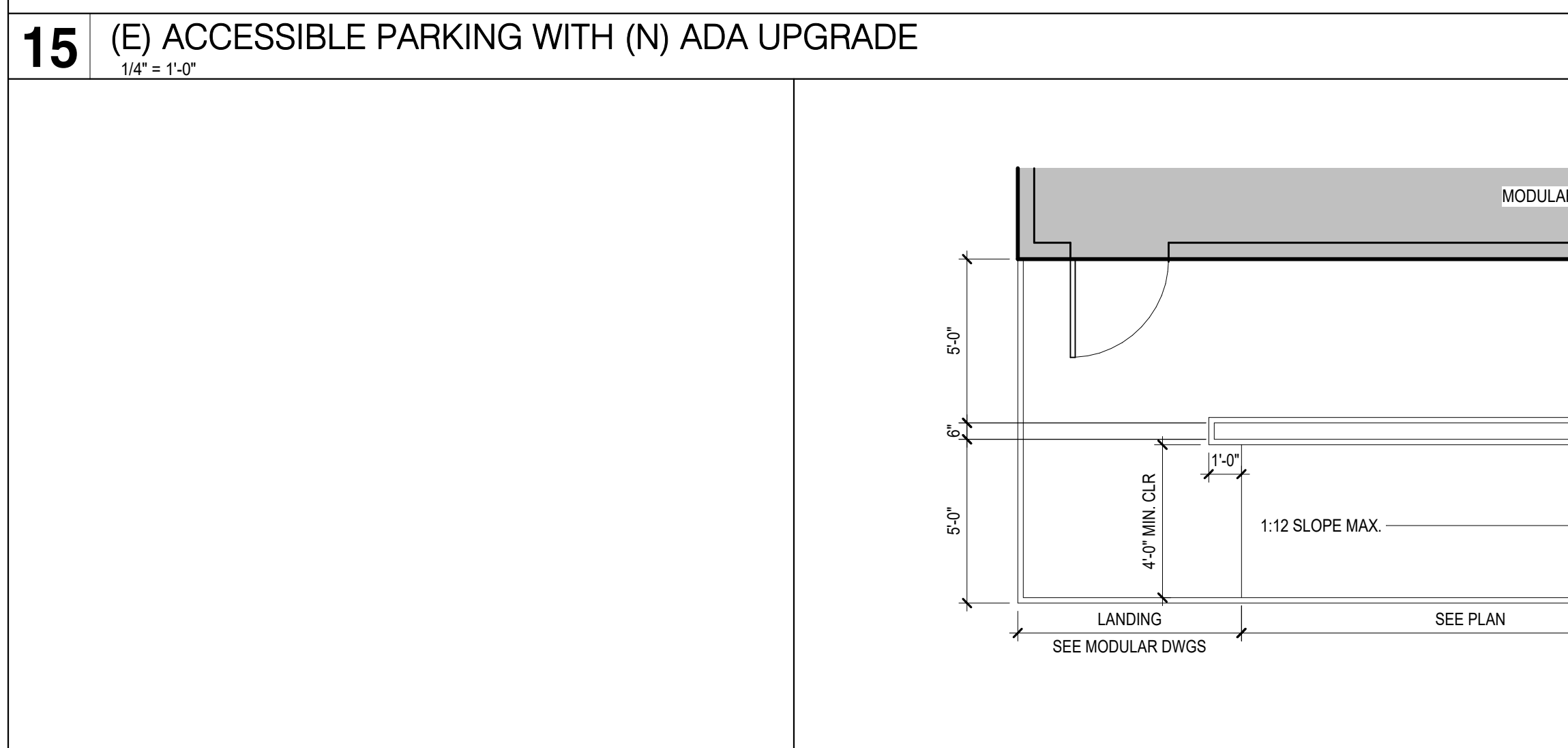
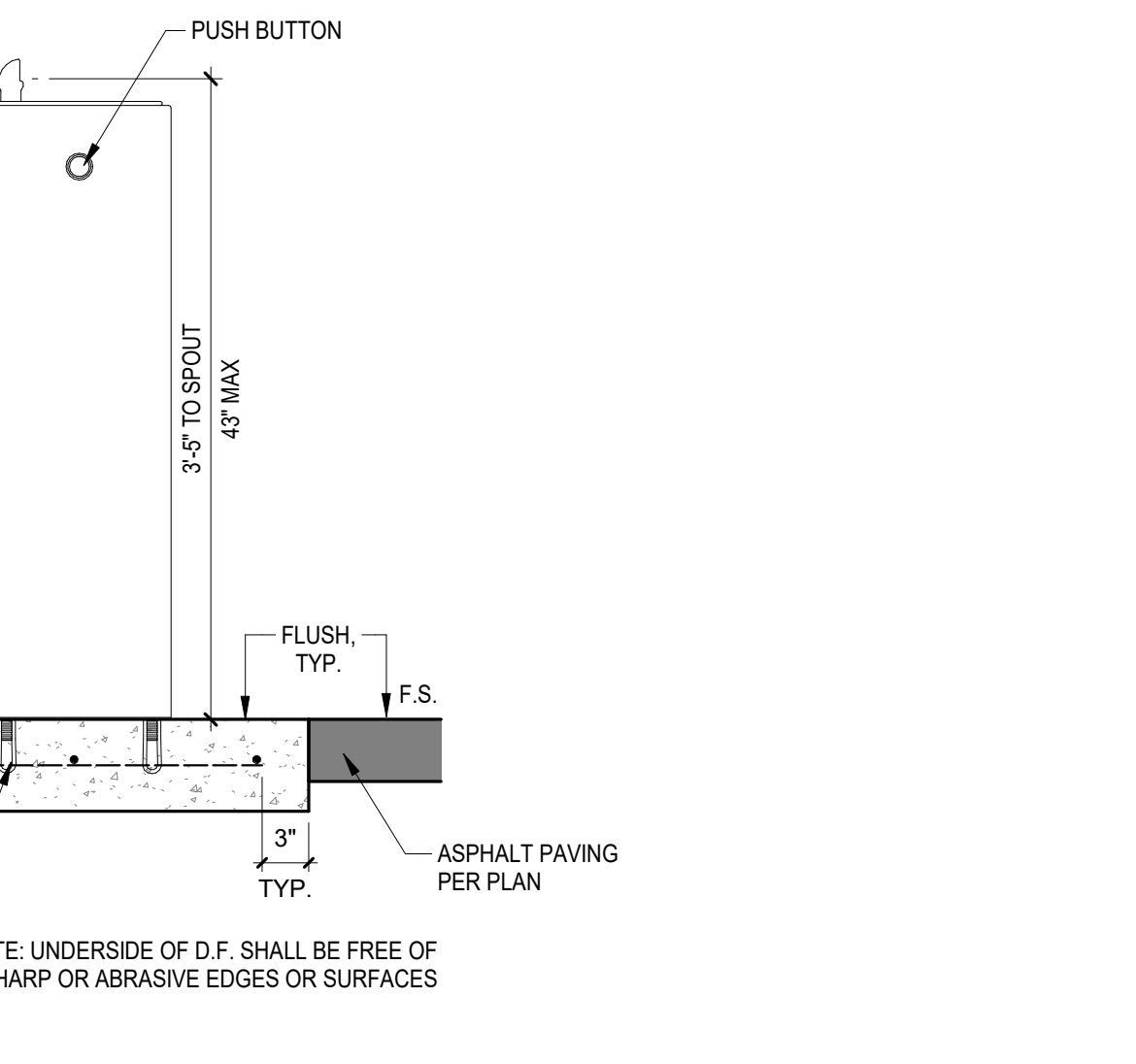
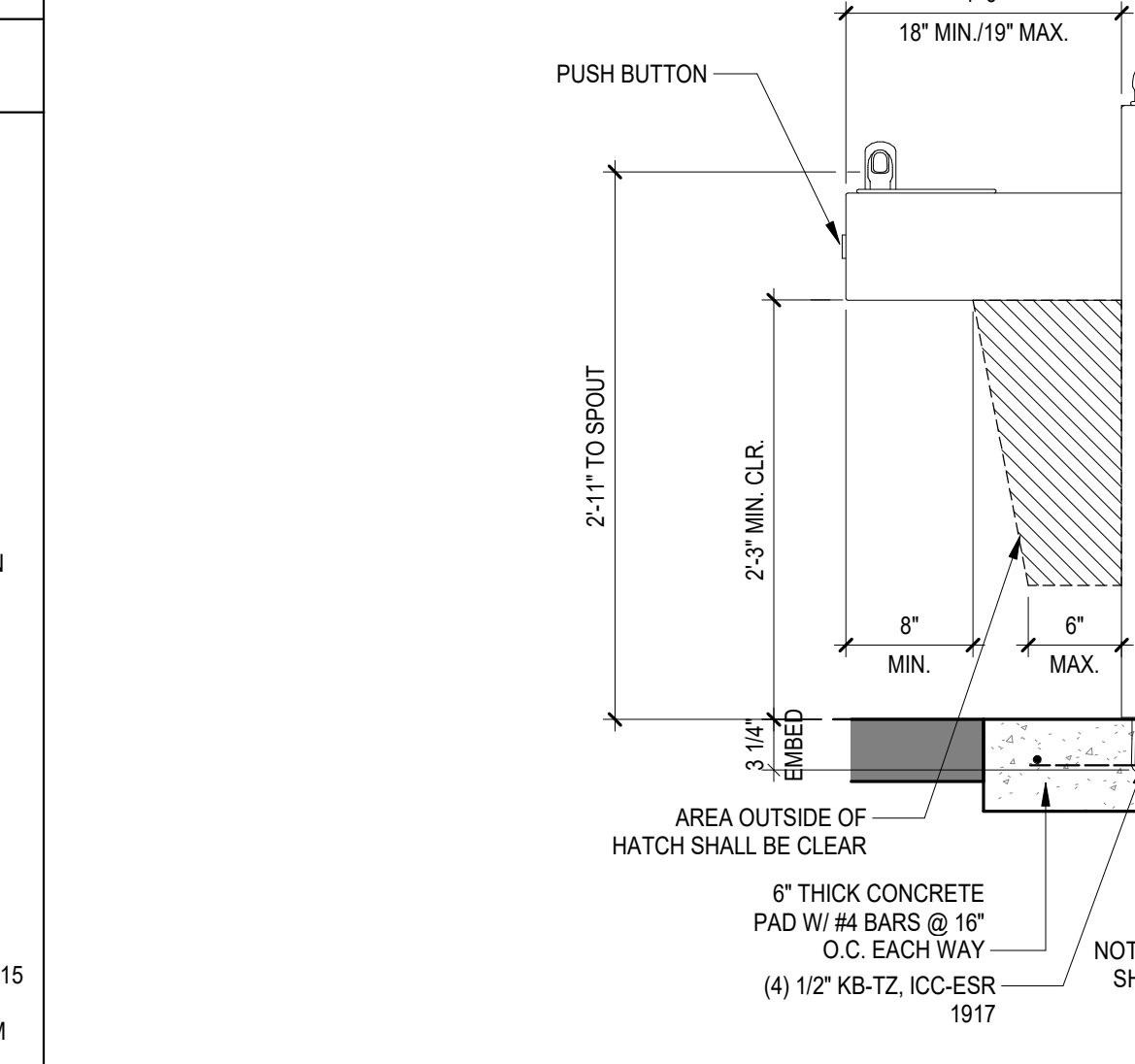

IDENTIFICATION STAMP
 DIV. OF THE STATE ARCHITECT
 APP: 03-121846 INC.
 REVIEWED FOR: [] SS [] FLS [] ACS []
 DATE: 11/05/2021

PRKWLC
 ARCHITECT: PRK Architects, Inc.
 SOUTHERN CALIFORNIA
 8163 Rochester Avenue, Suite 100
 Rancho Cucamonga
 California 91730-0729
 909-987-0999 P

Wedge worth ES Portable Relocation
 16949 WEDGEWORTH DR.
 HACIENDA HEIGHTS, CA 91745
 CONSTRUCTION DOCUMENTS
 DSA-APPL. NO. 03-121846 DSA-FILE NO. 19-38

HACIENDA LA PUENTE UNIFIED SCHOOL DISTRICT

KEY PLAN
 NORTH PLAN TRUE

ARCHITECT: LICENSED ARCHITECT
 STATE OF CALIFORNIA
 No. C-28195
 REG. 5-31-2025

CLIENT: HACIENDA LA PUENTE USD
 DATE: 10/12/2021 PROJECT NUMBER: P2127100AR
 DRAWING HISTORY:
 No. Description Date

CONSTRUCTION DOCUMENTS
 BUILDING NUMBER

DETAILS
A1.02